



#### Product description

Paper holder with mobile shelf

Material: Stainless steel 304

Finish: Polished finish

#### Technical specifications:

Paper holder with mobile shelf. The product consists of a wall mount and a paper roll. The shelf, made of stainless steel 304, is attached to the rod, which is made of stainless steel 304. The shelf has two holes so it can be fixed to the wall by means of screws. The assembled set has a polished finish that provides it an appropriate resistance against corrosion. The product is anchored to a brick wall by means of 2 nylon wall plugs and 2 screws. The overall dimensions of the product are 92 x 180 x 78 mm. The accessory model for the HORECA sector is GW05 37 04 02, manufactured by GENWEC WASHROOM S.L. - Av. Joan Carles I, 46-48 08908 L'Hospitalet de Llobregat.

#### Technical characteristics

##### Product specifications

- Paper shelf and rod made of stainless steel 304
- The metal parts have a polished finish that provides them an appropriate resistance against corrosion

##### Packaging specifications

- Type of individual package: Individual cardboard box and bubble wrap

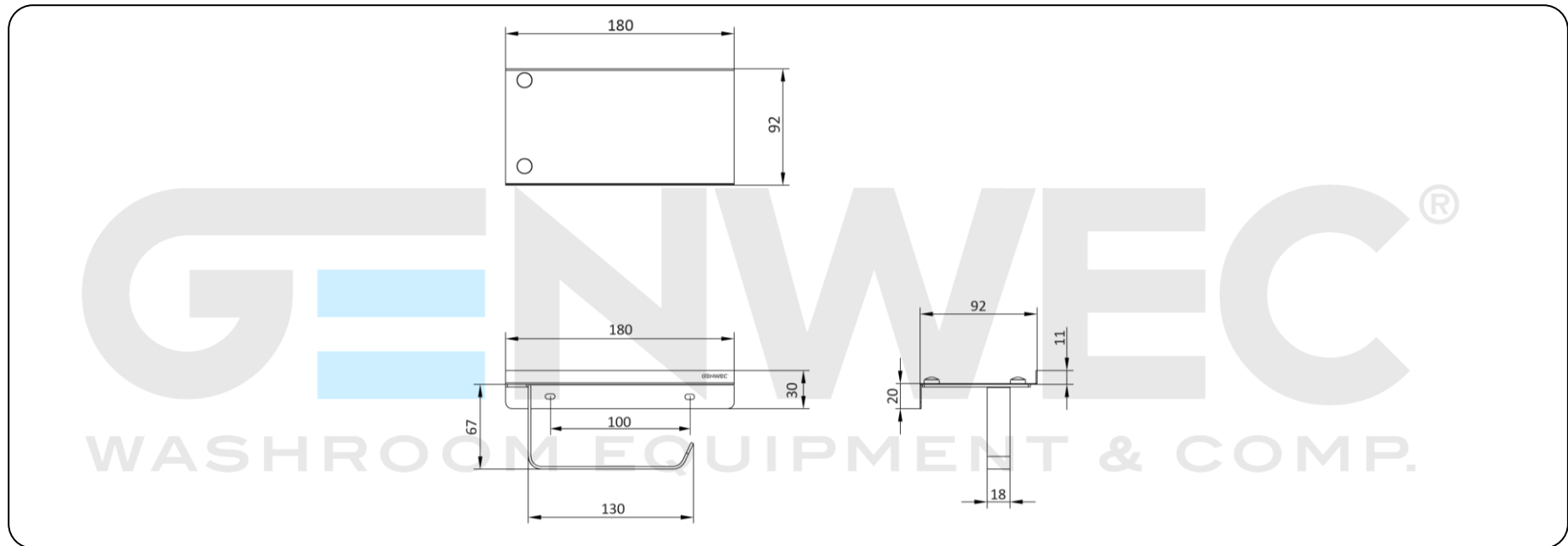

**Cleaning:** A cotton cloth slightly dampened in a soapy solution is recommended. Then dry off.