

LIQUID SOAP DISPENSER WH2



70 x 172 x 90 mm

200 ml soap tank

- Liquid soap dispenser in robust, germ-reducing and easy-care stainless steel (AISI 316L).
- All-stainless steel housing; visible surfaces satin finished and brushed.
- One-hand operated and non-drip soap pump with 200 ml tank.
- Tank with large, lockable refill opening.
- Designed for standard liquid soaps or hand lotions. Not suitable for disinfectants!
- Inspection slot to indicate fill level.
- Accessible for refilling through hinged housing.
- With spring-clip locking.
- Wear parts can be replaced as modules.
- Mounting: For glueing or with four screws through key holes and one optional anti-theft hole in the back wall.
- Delivery includes fixing material and first fill with soap..
- Weight, including single package: 1.3 kg



Suggested text for specifications:

Liquid soap dispenser in stainless steel (AISI 316L) for surface mounting. All-stainless steel housing; visible surfaces satin finished and brushed. One-hand operated and non-drip soap pump with 200 ml tank. Designed for standard liquid soaps or hand lotions. Inspection slot to indicate fill level. Accessible for refilling through hinged housing. With spring-clip locking. Delivery includes fixing material and first fill with soap.

Dimensions: 70 x 172 x 90 mm

Article No. WH2

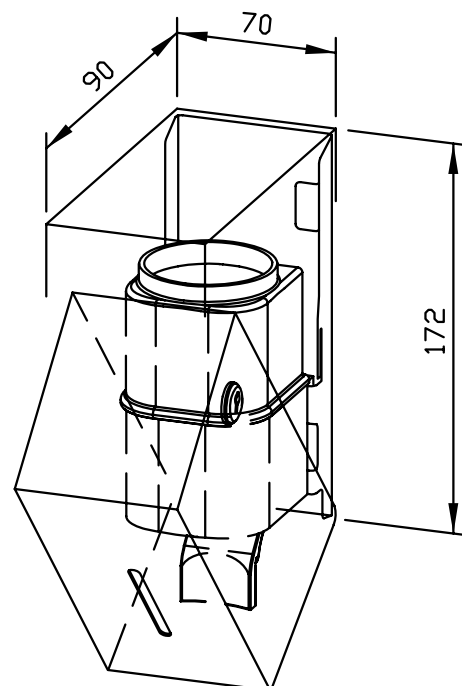

Available surfaces	ID No.
satin finished (standard)	727 345

Ernst Wagner GmbH & Co. KG

Ernst-Abbe-Straße 21 · D-72770 Reutlingen · Tel.: +49712151539-0 · Fax: -20
info@wagner-ewar.de · www.wagner-ewar.de

WAGNER
EWAR